

LM2642 Evaluation Board

National Semiconductor
Application Note 1239
Allan Fisher
March 2006



Introduction

The LM2642 evaluation board has been developed to aid in the design and evaluation of dc/dc converters based on the LM2642 controller IC. As shown in *Figure 1*, the evaluation board is configured to provide two outputs of 2.5V/2A and 1.8V/2A from an input range of 4.5V to 20V. The corresponding bill of materials is given in *Table 1*. *Figure 2* and *Figure 3* show the evaluation board layout.

Optional Components

The evaluation board provides several optional component pads for flexibility in changing components.

Please refer to the LM2642 product datasheet for more information regarding device operation and component selection.

In switching power supplies, the rapid increase of drain current in the top FET coupled with parasitic inductance will generate unwanted $L\Delta i/\Delta t$ noise spikes at the source node of the FET (SWx node) and also at the VIN node.

The resistor in series with the SWx pin (**R6**, **R11**) slows down the gate drive (HDRVx), thus slowing the rise and fall time of the top FET, yielding a longer drain current transition time and reducing switch node ringing. Top FET switching losses will increase with higher resistance values. Small resistors (1-5 ohms) can also be placed in series with the CBOOTx pin (**R7**, **R12**). A CBOOT resistor will slow the rise time of the FET, to reduce switch node ringing.

To maintain stable regulation, the FBx pins should remain free of noise. The LM2642 evaluation board has components **C15** and **C22** installed to suppress noise that may be picked up by the FBx traces. Notice that both of these capacitors are placed physically close to the FBx nodes. Pads **C17** and **C23** are provided for additional output capacitors.

Powering Up

Before powering up the LM2642 evaluation board, all external connections should be verified. The power supply input must be turned off and connected with proper polarity to the VIN post, also marked as **P1**. The channel 1 and channel 2 loads should be connected at the Vout posts, marked as **P2** and **P3**. Any type of load is acceptable up to 2A. The load can be on or off at startup. Output voltage can be monitored with a DVM or oscilloscope by connecting probes to the Vout posts, P2 and P3. The GND posts are provided primarily for scope probe ground connections. The PGOOD signal can be monitored with a scope probe or DVM at the **PGOOD** test pin.

Once all connections have been verified, input power can be applied. The input voltage must be set between 4.5V and 20V. The enable switches for each channel, **ON1** and **ON2**, can be used to turn on the evaluation board once the input power is on. Each channel may be enabled or disabled independently. The switches may also be left on for enabling the evaluation board directly from the power supply input.

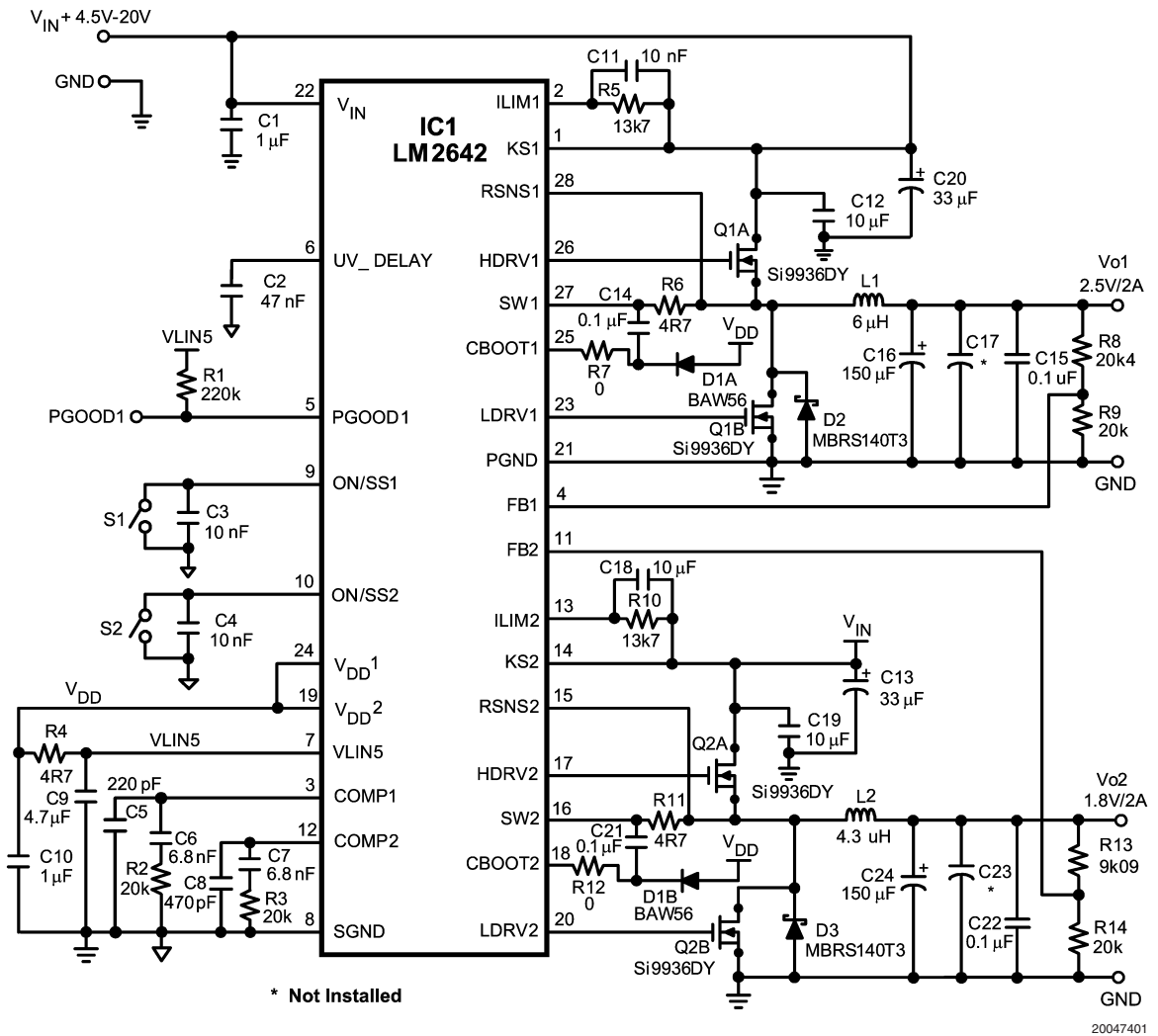

20047401

FIGURE 1. Complete Evaluation Board Schematic

TABLE 1. Bill of Materials

Part #	Value	Supplier
C1	Cer Cap 1F 50V Y5V 0805	Taiyo Yuden UMK212F105ZG
C2	Cer Cap 47nF 50V 10% 0805	Vishay VJ0805Y473KXA
C3	Cer Cap 10nF 50V 10% 0805	Vishay VJ0805Y103KXA
C4	Cer Cap 10nF 50V 10% 0805	Vishay VJ0805Y103KXA
C5	Cer Cap 220pF 25V 10% 0805	Vishay VJ0805Y221KXA
C6	Cer Cap 6.8nF 50V 10% 0805	Vishay VJ0805Y682KXA
C7	Cer Cap 6.8nF 50V 10% 0805	Vishay VJ0805Y682KXA
C8	Cer Cap 470pF 25V 10% 0805	Vishay VJ0805Y471KXA
C9	Cer Cap 4.7 μ F 10V X7R 1206	Taiyo Yuden LMK316BJ475ML
C10	Cer Cap 1 μ F 10V X7R 0805	Taiyo Yuden LMK212BJ105ZG
C11	Cer Cap 10nF 50V 10% 0805	Vishay VJ0805Y103KXA
C12	Cer Cap 10 μ F 35V Y5V 1210	Taiyo Yuden GMK325F106ZH
C13	Electro Cap 33 μ F 50V	Panasonic EEU-FC1H330
C14	Cer Cap 0.1 μ F 50V 10% 0805	Vishay VJ0805Y104KXA
C15	Cer Cap 0.1 μ F 50V 10% 0805	Vishay VJ0805Y104KXA
C16	Cap-SP 150 μ F 6.3V 20%	Panasonic EEFUEOJ151R
C17	Not Installed	
C18	Cer Cap 10nF 50V 10% 0805	Vishay VJ0805Y103KXA
C19	Cer Cap 10 μ F 35V Y5V 1210	Taiyo Yuden GMK325F106ZH
C20	Electro Cap 33 μ F 50V	Panasonic EEU-FC1H330
C21	Cer Cap 0.1 μ F 50V 10% 0805	Vishay VJ0805Y104KXA
C22	Cer Cap 0.1 μ F 50V 10% 0805	Vishay VJ0805Y104KXA
C23	Not Installed	
C24	Cap-SP 150 μ F 6.3V 20%	Panasonic EEFUEOJ151R
D1	Switching Diode-Dual 70V 200mA BAW56F	Fairchild BAW56F
D2	Schottky Diode 40V 1A	On Semiconductor MBR5140T31A
D3	Schottky Diode 40V 1A	On Semiconductor MBR5140T31A
L1	Inductor 6 μ H	Sumida CEP125-6R0MC
L2	Inductor 4.3 μ H	Sumida CEP125-4R3MC
Q1	Si9936DY	Vishay
Q2	Si9936DY	Vishay
R1	Res 220k Ω 0.1W 5% 0805	Vishay CRCW0805224J
R2	Res 20k Ω 0.1W 5% 0805	Vishay CRCW0805203J
R3	Res 20k Ω 0.1W 5% 0805	Vishay CRCW0805203J
R4	Res 4.7 Ω 0.1W 5% 0805	Vishay CRCW08054R7J
R5	Res 13.7k Ω 0.1W 1% 0805	Vishay CRCW08051372F
R6	Res 4.7 Ω 0.1W 5% 0805	Vishay CRCW08054R7J
R7	Res 0 Ω 0.1W 5% 0805	Vishay CRCW08050RJ
R8	Res 20.5k Ω 0.1W 1% 0805	Vishay CRCW08052052F
R9	Res 20k Ω 0.1W 1% 0805	Vishay CRCW08052002F
R10	Res 13.7k Ω 0.1W 1% 0805	Vishay CRCW08051372F
R11	Res 4.7 Ω 0.1W 5% 0805	Vishay CRCW08054R7J
R12	Res 0 Ω 0.1W 5% 0805	Vishay CRCW08050RJ
R13	Res 9.09k Ω 0.1W 1% 0805	Vishay CRCW08059092F
R14	Res 20k Ω 0.1W 1% 0805	Vishay CRCW08052002F
S1	Switch SPST 0.4VA 28V AC/DC A12AB	NKK A12AB
S2	Switch SPST 0.4VA 28V AC/DC A12AB	NKK A12AB

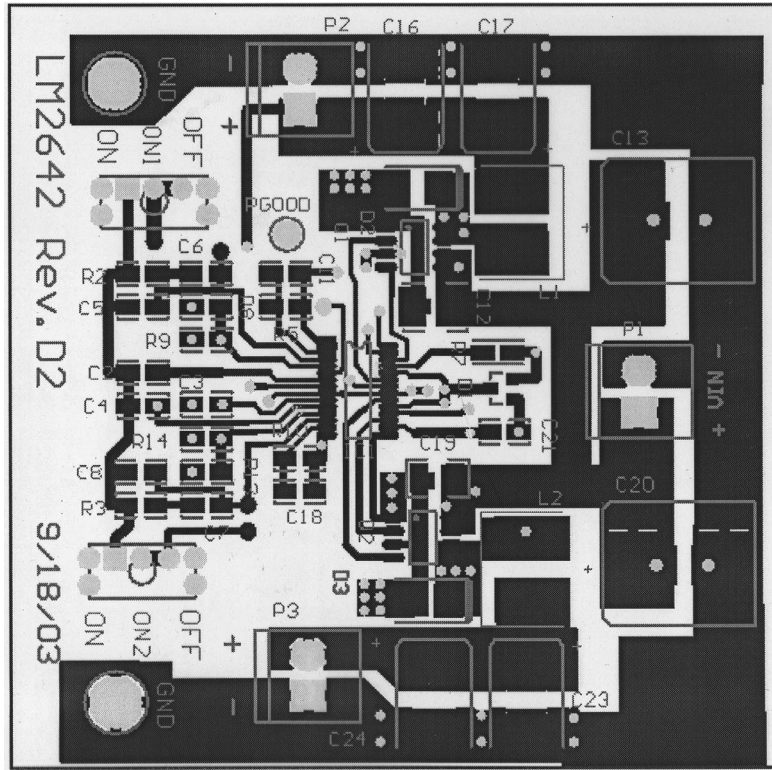

20047446

FIGURE 2. Top Layer

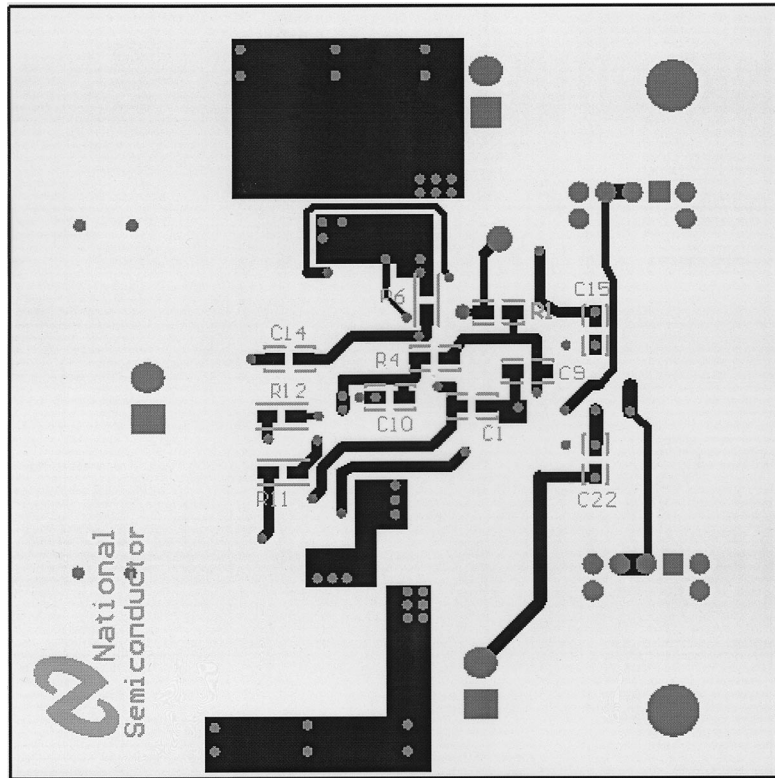

20047447

FIGURE 3. Bottom Layer

National does not assume any responsibility for use of any circuitry described, no circuit patent licenses are implied and National reserves the right at any time without notice to change said circuitry and specifications.

For the most current product information visit us at www.national.com.

LIFE SUPPORT POLICY

NATIONAL'S PRODUCTS ARE NOT AUTHORIZED FOR USE AS CRITICAL COMPONENTS IN LIFE SUPPORT DEVICES OR SYSTEMS WITHOUT THE EXPRESS WRITTEN APPROVAL OF THE PRESIDENT AND GENERAL COUNSEL OF NATIONAL SEMICONDUCTOR CORPORATION. As used herein:

1. Life support devices or systems are devices or systems which, (a) are intended for surgical implant into the body, or (b) support or sustain life, and whose failure to perform when properly used in accordance with instructions for use provided in the labeling, can be reasonably expected to result in a significant injury to the user.
2. A critical component is any component of a life support device or system whose failure to perform can be reasonably expected to cause the failure of the life support device or system, or to affect its safety or effectiveness.

BANNED SUBSTANCE COMPLIANCE

National Semiconductor manufactures products and uses packing materials that meet the provisions of the Customer Products Stewardship Specification (CSP-9-111C2) and the Banned Substances and Materials of Interest Specification (CSP-9-111S2) and contain no "Banned Substances" as defined in CSP-9-111S2.

Leadfree products are RoHS compliant.



National Semiconductor
Americas Customer
Support Center
Email: new.feedback@nsc.com
Tel: 1-800-272-9959

www.national.com

National Semiconductor
Europe Customer Support Center
Fax: +49 (0) 180-530 85 86
Email: europe.support@nsc.com
Deutsch Tel: +49 (0) 69 9508 6208
English Tel: +44 (0) 870 24 0 2171
Français Tel: +33 (0) 1 41 91 8790

National Semiconductor
Asia Pacific Customer
Support Center
Email: ap.support@nsc.com

National Semiconductor
Japan Customer Support Center
Fax: 81-3-5639-7507
Email: jpn.feedback@nsc.com
Tel: 81-3-5639-7560